

2-65 Series Casters

RWM's 2-65 Series Kingpinless™ Dual Wheel Casters feature all of the benefits of our patented Kingpinless™ raceway and twice the capacity load.

Features

Raceway Design: Patented Kingpinless™ single ball bearing precision machined raceway hardened to 53 Rockwell C minimum. Swivel section features a 2-3/8" diameter raceway with 3/8" ball bearings. The notched yoke is standard. All swivel sections are supplied with a lubrication fitting for field maintenance.

Axle: 1/2" diameter with lubrication fitting and lock nut

Finish: Zinc plated to protect from corrosion

Wheels: All wheels are 1-1/2" wide with a 3/4" I.D. roller bearing which rotates on a single 3/4" O.D. spanner bushing for ease of rollability. All bearings are pre-lubricated.

Mounting Plate Size: 4" x 4-1/2" x 1/4"

Bolt Hole Spacing: 2-5/8" x 3-5/8" slotted to 3" x 3"

Mounting Bolt Diameter: 3/8"

Leg Thickness: 1/4" formed steel

Applications

Dual wheel casters offer high weight capacities with minimal overall heights, better load distribution, floor protection and mobility than single wheel casters. This is a result of spreading the weight over a wider floor area while offering wheel differential action, resulting in less friction between the wheels and the floor, requiring less effort for the caster to swivel. Dual wheel casters are ideal for tow lines, shock load applications and abusive conditions, production line dollies & trucks used in various industries including but not limited to boat & ship molding and building, automotive, aerospace, metal fabricating, metal forging, heavy machinery & equipment, military equipment, mobile homes, etc. tractor pulled trailers, extreme duty platform trucks & material handling carts, air cargo & ground support equipment, storage tanks, gantries & heavy duty processing equipment, coliseum & gymnasium equipment, shipping / receiving carts, warehousing & freight terminal dollies and carts, and other extra heavy duty applications.

The Majority of Competitor's Raceways

The inline positioning of the competition's raceway (as opposed to the offset positioning utilized by RWM) creates a direct "hammering" effect via the ball bearings which are centered on the tangent of the two raceways, thus savaging and eventually eroding the raceway. The inevitable result is a loose fit and progressive swivel failure. Even a double raceway configuration is subject to these same "hammering" hazards.

The machining requirements of the competition to accommodate a swivel lock reduces strength, leading to premature fatigue, stress fractures of the raceway and eventual failure.

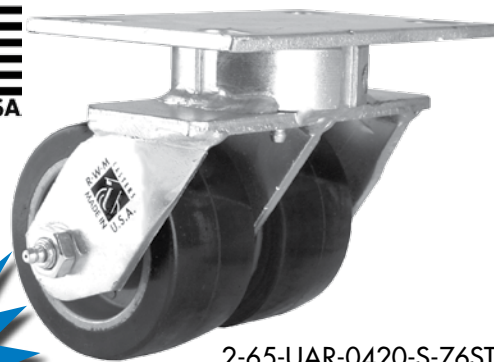

2-65-UAR-0420-S-76ST

View
CAD Models
On Our
Website!

Options

- CWB** Cam Wheel Brake
- DSL** Demountable Swivel Lock
- HT** High Temperature Lubrication
- LT** Low Temperature Lubrication
- SL** Swivel Lock
- SR** Sealed Swivel Raceway
- TG** Thread Guard

RWM's Patented Offset Raceway – Why It's a Superior Design

Our patented offset precision-machined raceway exerts radial force evenly where there is full contact between the ball bearing and the raceway. RWM's unique design adds more mass at key points. This, plus more thorough heat treatment, provides additional strength and combats brinelling into the core material. The result:

- ◆ No direct "hammering" forces on the intersections of the raceways
- ◆ Vastly reduced raceway wear
- ◆ Elimination of the "pull apart" forces of stress in the swivel section
- ◆ Smoother swiveling action
- ◆ High maneuverability
- ◆ Longer service life
- ◆ Less maintenance
- ◆ Extra impact resistance
- ◆ High radial force absorption

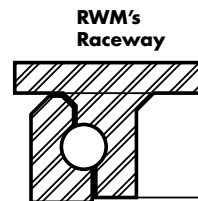

Competitor's Raceway

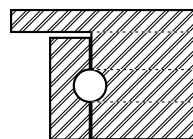

UP TO 2,000 POUND CAPACITY

SPECIFICATIONS

Wheel Diameter	Wheel Width	Wheel Type	lbs. Capacity	Overall Height	Swivel Caster Model Number		Swivel Lead	Approx. Weight lbs.
					Straight Roller	Ball Bearing		
4"	1-1/2"	Cast Iron	1000	5-3/4"	2-65-CIR-0415-S	2-65-CIB-0415-S	1-1/8"	10.0
		Durastan	1200		2-65-DUR-0415-S	2-65-DUB-0415-S		8.0
		GT	1300			2-65-GTB-0415-S		8.0
		Performance TPR	650		2-65-RPR-0415-S	2-65-RPB-0415-S		8.0
		Rubber on Iron	500		2-65-RIR-0415-S			8.0
		Urethane on Aluminum	1200		2-65-UAR-0415-S			7.5
		Urethane on Iron	1200		2-65-UIR-0415-S	2-65-UIB-0415-S		8.0
		Urethane Polypropylene	1000		2-65-UPR-0415-S	2-65-UPB-0415-S		7.5
		Urethane Solid	600		2-65-USR-0415-S			8.0
5"	1-1/2"	Cast Iron	1200	6-3/4"	2-65-CIR-0515-S	2-65-CIB-0515-S	1-1/2"	12.0
		Durastan	1300		2-65-DUR-0515-S	2-65-DUB-0515-S		9.0
		GT	1600			2-65-GTB-0515-S		9.0
		Performance TPR	700		2-65-RPR-0515-S	2-65-RPB-0515-S		8.0
		Rubber on Iron	600		2-65-RIR-0515-S			9.0
		Urethane on Aluminum	1440		2-65-UAR-0515-S			8.5
		Urethane on Iron	1440		2-65-UIR-0515-S	2-65-UIB-0515-S		9.0
		Urethane Polypropylene	1400		2-65-UPR-0515-S	2-65-UPB-0515-S		8.0
		Urethane Solid	660		2-65-USR-0515-S			9.0
6"	1-1/2"	Cast Iron	1200	7-3/4"	2-65-CIR-0615-S		1-1/2"	13.0
		Durastan	1600		2-65-DUR-0615-S	2-65-DUB-0615-S		10.0
		GT	1700			2-65-GTB-0615-S		10.0
		Performance TPR	700		2-65-RPR-0615-S	2-65-RPB-0615-S		8.0
		Rubber on Iron	740		2-65-RIR-0615-S			10.0
		Urethane on Iron	1680		2-65-UIR-0615-S	2-65-UIB-0615-S		12.0
		Urethane Polypropylene	1600		2-65-UPR-0615-S	2-65-UPB-0615-S		11.0

To order a rigid caster, change the "S" to "R" in the model number. For example: "2-65-CIR-0415-R". To order rig only, omit the blue letters. For example: "2-65-0415-S". Dimensions shown are nominal. If precise dimensions are required, consult your RWM representative. For approximate weight of our rigid casters, deduct 5.4 pounds per item.

OPTIONAL MOUNTING PLATES

Optional Top Plate Number	Mounting Plate	Bolt Hole Spacing	Bolt Size
41ST 41RT	4" x 5"	2-5/8" x 3-5/8" slotted to 3" x 4"	3/8"
42ST 42RT	4-1/2" x 6-1/2"	2-7/16 x 4-15/16 slotted to 3-3/8" x 5-1/4"	1/2"
43ST 43RT	5" x 5-1/2"	4-1/8" x 4-1/2"	3/8"

UP TO 2,000 POUND CAPACITY